

SOMERSET

Tel: 978.667.3355

800.772.4404

Fax: 978.671.9466

Email: somerset@smrset.com

www.smrset.com



CDR-500

DOUGH • SHEETER

Ideal for:

- Cinnamon Rolls
- Yeast Raised Donuts
- Danishes
- Pastry Production
- Dough Lamination
- Pie Crusts
- Pizza
- Pasta
- Fondant

Highlights:

- Ships standard with synthetic, non-stick rollers
- Sheets 500-600 pcs. per hour
- Ergonomic design makes it easy and simple to operate
- All stainless steel construction offers safety, sanitation, speed, simplicity, durability, and low cost

The most versatile tabletop sheeter available!



The ultimate sheeter! Sheets dough to a uniformed thickness in seconds!

Features

- Simple handle adjustments for exact uniform dough thickness
- Synthetic rollers eliminate dough build up
- Safety sensors for automatic shutoff
- Compact design, ideal for use in limited space
- Ergonomic design for easy operation
- Convenient side operation
- Maintenance free drive mechanism
- Drive mechanism isolated from roller area
- Safe, simple, easy to operate, easy to clean
- Sanitary, heavy duty, all stainless steel welded construction
- Spring loaded scrapers readily removable for easy cleaning



Available with metallic rollers
(please specify CDR-500M)

Industry Uses:

- Bakeries
- Donut Shops
- Institutions
- Schools
- Hospitals
- Pizzerias

Specifications

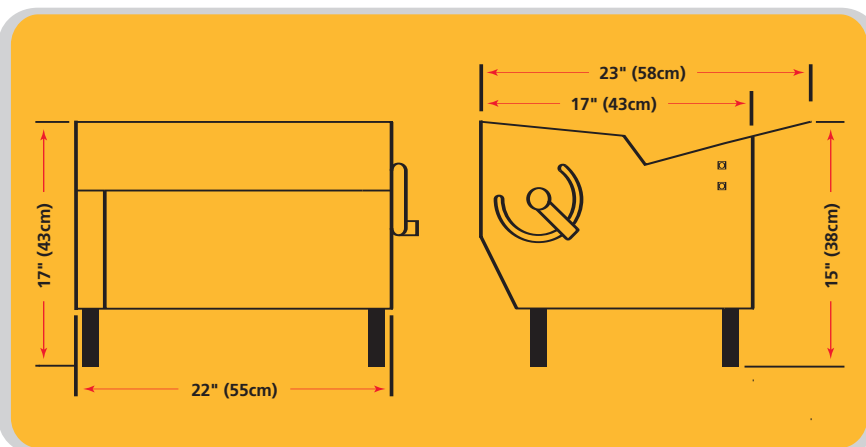

Rollers: 3.5" (8.89 cm) dia. by 20" (50.80 cm) length

Scrapers: Synthetic, Spring Loaded, Removable

Bearings: Sealed Ball Bearings, Permanently Lubricated

Gear Motor: Heavy Duty 3/4 HP, Maintenance Free, Single Phase, 115v/60Hz or 220v/50Hz

Finishing: All Stainless Steel

Legs: 4" Adjustable, Stainless Steel

Shipping Weight: 150 lbs (68 kgs)